

Estimating Roof Covering 3

YOUR OBJECTIVE:

To estimate the amount of roof covering needed for a job, it is necessary to know:

- The area of the roof
- The length of eaves, ridges, hips, rakes, and valleys.

Most roofers use rules of thumb to estimate roofing. There is nothing wrong with that approach if you understand the foundation for the rule of thumb. This chapter presents both the detailed calculation for a shingle estimate and also a useful rule of thumb approach. When you understand the details you will be able to develop estimating shortcuts of your own.

However, remember that estimating is not selling. This chapter shows you how to estimate the number of shingles you will need. However, that is seldom the whole job. More important, it says nothing about the selling proposition, the selling of your services and products to the homeowner. The homeowner needs to trust you to give you the work. Showing him the calculations is one way to add a level of trust. With a computer it is easy to produce a detailed estimate on a spread-sheet. The worksheets laid out in this chapter can be used for computer spreadsheets. They will produce a detailed estimate as fast as you can collect the dimensions and plug them in. Use a spread sheet as an integrated part of your closing strategy.

ESTIMATING THE AREA OF A ROOF

Roof areas can be broken down into several basic shapes:

- ◆ Rectangle
- ◆ Triangle
- ◆ Trapezoid (rectangle, triangle, and parallelogram)

There are several ways to obtain the dimensions of the roof. These include:

1. Climb the roof and make direct measurements on the roof.
2. Observe the roof from the ground. Use various techniques we describe to break down the area into rectangles and triangles. Make a plan view.
3. Use existing plans of the building to obtain dimensions of the roof.

GABLE ROOFS

DIRECT MEASURE

Consider the gable roof in *Figure 3-1*. The area of this roof is made up of two rectangles. The area of each rectangle is $A \times B$. Therefore by measuring A and B directly the area of the gable roof is:

$$\text{Area} = 2 \times A \times B$$

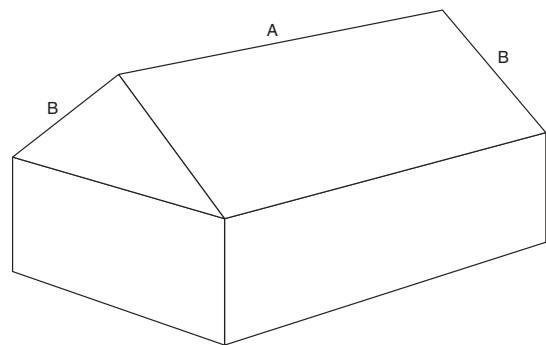

Figure 3-1: Direct Measure

WORKING FROM A PLAN VIEW

However, we can describe the roof in another way. Suppose we walk around the building and measure the length and width of the building. We can now draw a flat representation of the building at the ground level called the plan view. We have projected the inclined roof onto a horizontal surface to get the area shown in *Figure 3-2*. The dimension B, the rake, now appears as Y on the plan view.

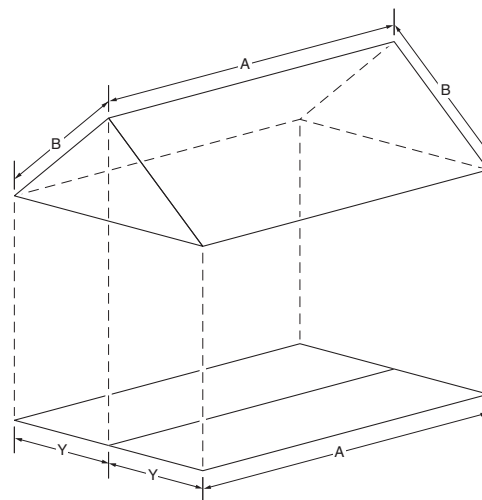
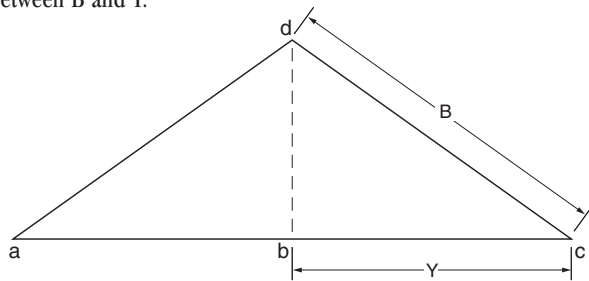

Figure 3-2: Plan View

In this view, the projected length of the eaves and the projected length of the ridge (both A), are correct actual lengths. However, Y does not equal B. To use Y to determine the actual length of B we need the concept of slope.

SLOPE OF A GABLE ROOF

In the cross section of the roof shown in *Figure 3-3* (a projection onto a horizontal plane), we can see the difference in length between B and Y.



$$\text{Slope} = \frac{bd}{bc} = \frac{\text{rise}}{\text{run}} \quad \text{Span} = ac$$

Figure 3-3

The slope of the roof is defined as the rise of the roof (bd in *Figure 3-3*) divided by the run of the roof. (bc in *Figure 3-3*). A 5" rise with a 12" run is said to have a 5/12 slope. The slope measures how steep the roof is. If we know the rise of the roof and the run of the roof, we can calculate B ($B=Y \times \text{slope factor}$) – which is the actual rake length – from Y, and easily figure the area.

Below is a table of slope factors to make the calculation of the rake length (B) easy. If we know the rise in elevation of the roof for every foot of run, then we multiply the area of the horizontal plane ($2Y \times A$ in *Figure 3-2*) by the corresponding slope factor in Table 1 to get the actual area.

Table 1

Rise inches/ft	Slope factor
4	1.054
5	1.083
6	1.118
7	1.157
8	1.202
9	1.250
10	1.302
11	1.356
12	1.414

For example, if the rise is 5 inches per foot, then the area of the roof in *Figure 4-2* is:

$$\begin{aligned} \text{Area} &= (\text{Area on plan view}) \times (5 \text{ inch rise slope factor}) \\ &= (2 Y \times A) \times (1.083) \end{aligned}$$

Let us calculate the area of a simple gable roof like *Figure 3-4*.

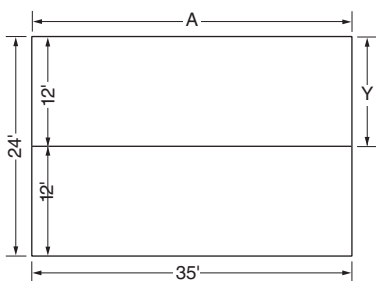

Figure 3-4: Plan view with dimensions.

$$\begin{aligned} \text{Area} &= 2 \times Y \times A \times (5 \text{ inch slope factor}) \\ &= 24 \text{ ft.} \times 35 \text{ ft.} \times 1.083 \\ &= 909.72 \text{ square ft. (910 sq. ft.)} \end{aligned}$$

Three other measurements required to estimate materials for the gable roof are:

- ◆ ridge length
- ◆ eaves length
- ◆ rake length

We know the ridge and eaves length (35 ft. each).

To find the length of the rake, multiply the run (y) by the slope factor:

$$12 \times 1.083 = 12.9 \text{ ft.}$$

To calculate drip edge:

$$\text{Rakes: } 4 \times 12.9 = 51.6 \text{ ft.}$$

$$\text{Eaves: } 2 \times 35.0 = 70.0 \text{ ft.}$$

$$\underline{\hspace{1.5cm}} \\ 121.6 \text{ ft.}$$

Keep in mind that .6 ft. is NOT 6", but rather $\frac{6}{10}$ of a ft., or just over 7".

HIP ROOFS

The second roof discussed is the hip roof shown in a horizontal plan projection in *Figure 3-5*. All four sides of a **conventional** hip roof have the same slope. Note how the plan view is made up of two end triangles and two trapezoids. The trapezoid can be broken into two triangles and a rectangle. By breaking up the trapezoid, you can determine the length of the ridge. (See "*Useful Estimating Techniques*" on the next page to find the "run" of a hip.)

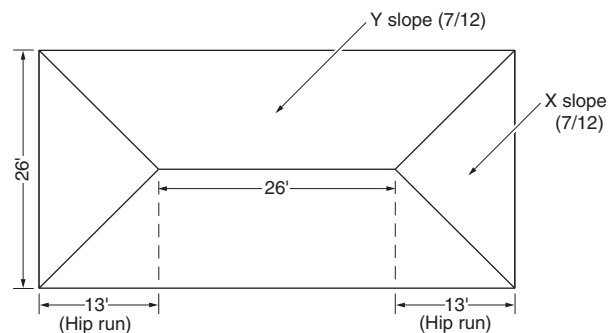

Figure 3-5: Conventional Hip Roof Plan View.

The slope for this roof is 7 inches per foot.

To calculate the total area of this roof, multiply the length x the width x the slope factor:

$$\begin{aligned} \text{Area} &= (13 \text{ ft.} + 26 \text{ ft.} + 13 \text{ ft.}) \times 26 \text{ ft.} \times (7" \text{ rise slope factor}) \\ &= 1352 \text{ ft.} \times 1.157 \\ &= 1564 \text{ square ft.} \end{aligned}$$

SLOPE FACTOR FOR HIPS AND VALLEYS

Finding the hip length in *Figure 3-5* is a different matter. To find a hip length, we must multiply the "run" of the hip (13 ft. in *Figure 3-5*) by the appropriate hip/valley factor in **Table 2**.

Table 2

Rise inches/ft	Hip/Valley factor
4	1.452
5	1.474
6	1.500
7	1.524
8	1.564
9	1.600
10	1.642
11	1.684
12	1.732

Here's a Tip... Always order one extra square of material per job in case some of the material becomes damaged due to rough transportation or rough handling on the job during loading and unloading.
(Thanks to Martin Kuypers of Sunderland, Ontario, Canada)

Therefore we find one hip length as follows:

$$\begin{aligned} \text{One hip length} &= (\text{Run of the hip}) \times (\text{Hip/Valley factor} \\ &\quad \text{for a 7 inch slope}) \\ &= 13 \text{ ft} \times 1.524 \\ &= 19.8 \text{ ft. (20 ft.)} \\ \text{Total hip length} &= 4 \times 20 \text{ ft} = 80 \text{ ft.} \end{aligned}$$

USEFUL ESTIMATING TECHNIQUES

When estimating the area of a hip roof, it is important to know the base of the hip triangle. It is also important to be able to determine the slope of the hip roof.

ESTIMATING TRIANGULAR SHAPES FROM THE GROUND

Here are two methods for finding the length of triangular shapes

A. TO FIND THE "RUN" OF A HIP

METHOD 1 can be used on a bare deck or a shingled roof.

- ◆ Stand on the ground, far enough back from the roof so that you can see the triangular shape easily.
- ◆ Take a plumb bob and align the end of the string with the top of the hip or peak of the triangular shape.
- ◆ Note where the bob hangs in relation to objects on the side of the house. Use window or shrubbery locations as a marker.
- ◆ Measure the actual distance from this marker to the position of the corner of the building plus the overhang (the lower corner of the triangular shape).

METHOD 2 can be used when there are shingles on the roof.

- ◆ From the top of the hip, follow the nearest tab cutout or shingle joint down the roof slope to the eaves edge.
- ◆ Count tabs across the lower hip edge.
- ◆ Calculate length based on the length of the tabs (12 inches for a three tab shingle or 36 inches for a no cut-out shingle).

B. DETERMINING ROOF SLOPE

FROM THE GROUND: The Sight Card is used to determine roof slope from the ground. To find the slope:

- ◆ Hold card so that the side with arrows is facing you.
- ◆ Hold card at arm's length and, standing in line with the roof peak, align an arrow with the roof peak.
- ◆ For gable roofs, hold the card vertical. For hip roofs, slant card toward the building with the same slant as the roof.
- ◆ Rotate the card from arrow to arrow until the sides of the card coincide with the sloping edges of the roof. The slope is listed under the arrow.

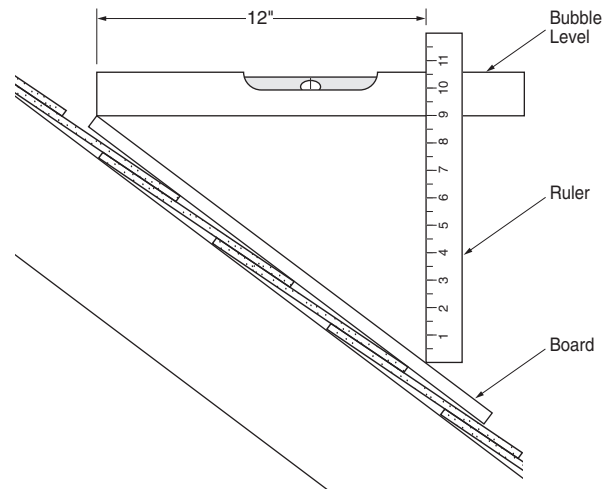

Figure 3-6: 9/12 slope.

ON THE ROOF: This method uses simple tools: a flat board, a bubble level and a ruler (Figure 3-6).

- ◆ Place board on slanted roof.
- ◆ Locate one edge of the bubble level on board at high, up-slope end.
- ◆ Mark bubble level one foot from up-slope end.
- ◆ Center bubble in level.
- ◆ Place ruler vertically at the one foot mark of the bubble level (down-slope end).
- ◆ Measure distance in inches from roof to bottom of the bubble level.
- ◆ The slope is then the rise (9") ÷ the run (12"), i.e. 9/12.

VALLEYS IN ELL ROOF

In Figure 3-7 we show an ell roof in plan view. This plan presents two common estimating problems when you work from plan dimensions.

1. The ell roof forms two valleys between roof planes with different slopes. The common approach to calculate valley lengths between roof planes with different slopes is to figure lengths for each slope and then average the two.
2. To find the roof area of the ell that joins the main roof we have to break the plan view into a rectangle and a triangle. To find the area of the triangle we have to use some basic geometry.

You will see that using plan view measurements makes it easy to figure different slope situations.

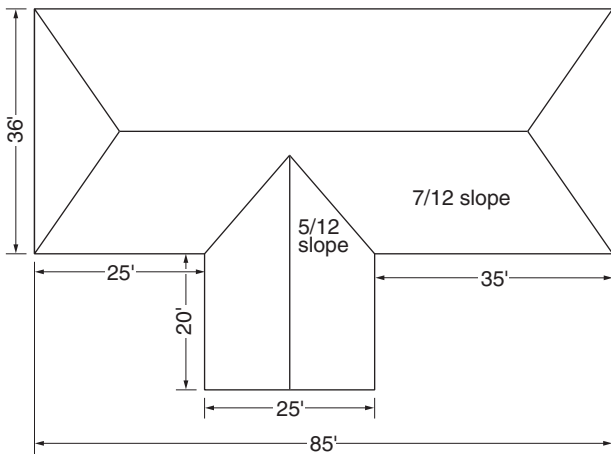

Figure 3-7

NOTE: The slope of the hip roof is 7/12, the slope of the ell is 5/12.

MAIN ROOF

It's a fairly simple matter to calculate the area of the main roof (length x width) except that you must subtract the portion of the main roof, a triangle, that is overlapped by the ell. So, let's work on that triangle first.

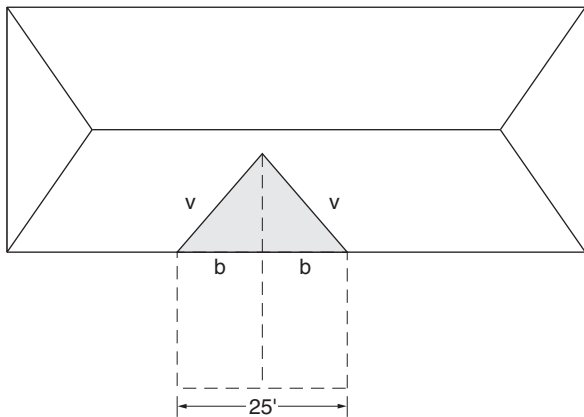

Figure 3-8: Valley Length (v), ell roof

To find the length of one valley:

1. Measure the front of the ell (25').
Divide by 2 to find b ($b = 25/2 = 12.5$).
2. Calculate for the ell roof with a 5/12 slope.
 $v = 12.5 \times 1.474 = 18.425$
3. Calculate for the main roof with a 7/12 slope.:
 $v = 12.5 \times 1.524 = 19.05$
4. Average the two slopes. $v = (18.425 + 19.05)/2 = 18.74$

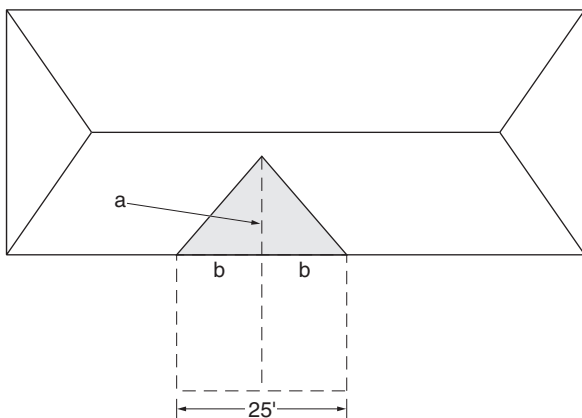

Figure 3-9

To find "a" Use this formula: $a^2 = v^2 - b^2$

(The formula for a right angle triangle is $v^2 = a^2 + b^2$, or $a^2 = v^2 - b^2$)

$$a^2 = (18.74)^2 - (12.5)^2$$

$$a^2 = 351.19 - 156.25$$

$$a^2 = 194.94$$

$a =$ the square root of a^2 . (Most hand calculators can do this.) = 13.96'

$a = 14'$ (rounded up)

The area of the triangle is $(a \times 2b)/2$

$$(14 \times 25)/2 = 175 \text{ sq. ft.}$$

We will use this area when we calculate the ell roof, too.

Now, calculate the plan area of the main hip roof.

$$= (36 \times 85) - \text{plan area of the triangle} = 3,060 - 175 = 2,885 \text{ sq. ft.}$$

Convert plan area to actual area.

$$= 2,885 \text{ sq. ft.} \times \text{slope factor } (7/12)$$

$$= 2,885 \text{ sq. ft.} \times 1.157$$

$$= 3,338 \text{ sq. ft. (rounded up)}$$

Remember: on a complex roof, if the slopes on the hips were not all the same, you would have to calculate each separately.

ELL ROOF

By doing the initial calculations in the plan view, conversion to 5/12 slope is not difficult.

Calculate plan area of the ell roof without the triangle.

$$= (25 \times 20)$$

$$= 500 \text{ sq. ft.}$$

Add the plan area of the triangle we figured above.

$$500 + 175 = 675 \text{ sq. ft.}$$

Figure actual roof area of the ell.

$$= 675 \text{ sq. ft.} \times 1.083 \text{ (5/12 slope factor)} = 731 \text{ sq. ft.}$$

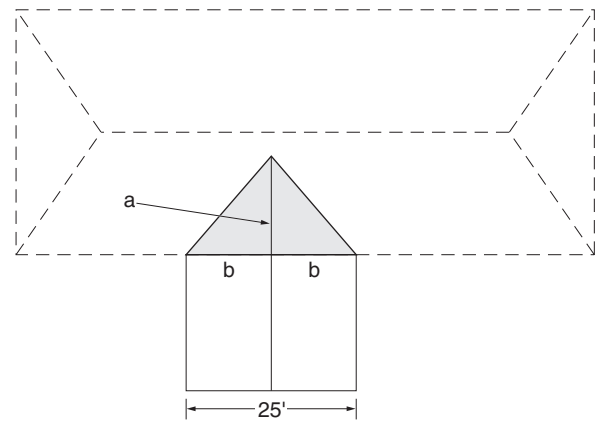

Figure 3-10

Roof area of ell and main roof:

Main roof 3,338 sq. ft.

Ell roof 731 sq. ft.

Sum 4,069 sq. ft. = **41 sqs. (1 sq. = 100 sq. ft.)**

SHINGLES

The total quantity of shingles required includes shingles for

- ◆ The starter course
- ◆ The hip and ridge sections
- ◆ The cutting-waste at rakes, hips and valleys
- ◆ The waste due to crew error

STARTER COURSE

The starter course is made of shingles from which the lower five inch tabs have been removed. If 36 inch-long shingles are used, the number of starter course shingles is calculated from:

Number of starter shingles = Total length of eaves in feet ÷ 3 ft.

Carefully include the required starter shingles in your total order for shingles. Underestimating can cause extra expense and delay on the job.

CUTTING WASTE AND SALVAGE (RAKES, HIPS & VALLEYS)

Assuming the use of 3 ft. x 1 ft. strip shingles, the cutting waste at rakes in square feet per linear foot of rake is calculated using the waste factor in Table 3. Other style shingles will have different waste and salvage factors.

Table 3

Waste and salvage factors for 3-tab shingles (sq. ft/ft)

Type	Waste Factor	Salvage factor
Rake	0.3	1.0
Hip	0.7	0.5
Open Valley	1.5	2.0
Closed Valley	2.2	1.0
Woven Valley	3.0	0

NOTE: On hip units you will require more units than will be salvaged. On the other hand, on gable roofs you will salvage more shingles than needed. This result requires that the salvaging is done very carefully.

CALCULATING WASTE

A. RULE OF THUMB: One way to avoid detailed calculations is to add 10% to the quantity of shingles for a gable roof and 15% for a hip roof. However, since the waste varies with size of the roof, 10% (or 15%) will be too high for larger roofs.

B. IMPROVED RULE OF THUMB: However, a more accurate estimate of waste, which depends on the size of the roof, can be made with **Table 4**.

Table 4
Approximate percent to use for waste

Area of roof (sq. ft)	Gable Roof percent	Hip Roof percent
600	8	17
1200	6	13
1500	5	11
2000	4	9
3200	3	8

SAMPLE ESTIMATES

GABLE ROOF (SIMPLE)

Consider estimating the shingles required for the gable roof shown in *Figure 3-11*. The slope is 6 inches per foot.

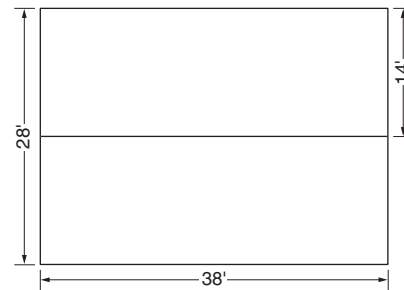

Figure 3-11

$$\begin{aligned} \text{Roof Area} &= 38 \text{ ft} \times 28 \text{ ft} \times \text{slope factor, 6 in/ft} \\ &= 38 \text{ ft} \times 28 \text{ ft} \times 1.118 = 1190 \text{ sq. ft (rounded up)} \end{aligned}$$

$$\begin{aligned} \text{Additional Area} &= \text{Starter course} + \text{Rake Cutting Waste} + \\ &\quad \text{Allowance (ridge)} \\ &= 76 \text{ ft starter course} + \text{Rake Cutting Waste} + \\ &\quad (\text{Salvage} - \text{Required at ridge}) \end{aligned}$$

$$\begin{aligned} \text{Rake Cutting Waste} &= \text{rake length} \times \text{slope factor} \times \text{waste factor} \\ &= 56 \text{ ft} \times 1.118 \times 0.3 \\ &= 19 \text{ sq. ft (rounded up)} \end{aligned}$$

$$\begin{aligned} \text{Allowance} &= \text{Salvage at rakes} - \text{Required at ridge} \\ &= 56 \text{ ft} \times 1.118 \times 1.0 \text{ sq. ft/ft} - 38 \text{ ft} \times 1 \text{ sq. ft/ft} \\ &= 24.6 \text{ sq. ft} \end{aligned}$$

$$\begin{aligned} \text{Total Area} &= 1190 \text{ sq. ft} + 76 \text{ ft Starter Course} + \\ &\quad 19 \text{ sq. ft (Rake Waste)} + 24.5 \text{ sq. ft Allowance} \\ &= 1233.6 \text{ sq. ft} + 76 \text{ ft Starter Course} \end{aligned}$$

This is equivalent to 1233.6 sq. ft (or 12.34 squares) plus the 76 ft Starter Course.

NOTE: This approach is an approximation – always round up to be safe.

HIP ROOF (CONVENTIONAL)

Next we estimate the number of shingles required for the conventional hip roof shown in *Figure 3-12*. The roof slope is 5/12.

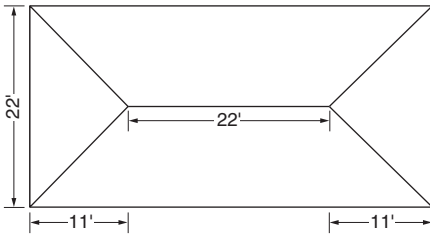

Figure 3-12

$$\text{Roof Area} = 44 \text{ ft} \times 22 \text{ ft} \times 1.083 = 1048 \text{ sq. ft}$$

$$\text{Length of Hip} = 11 \text{ ft} \times \text{Hip Factor} = 11 \text{ ft} \times 1.474 = 16.21 \text{ ft}$$

$$\text{Total Length of Hips} = 4 \times 16.21 = 65 \text{ ft (rounded up)}$$

$$\begin{aligned} \text{Cutting Waste at Hips} &= 65 \text{ ft} \times 0.7 \text{ sq. ft/ft} \\ &= 46 \text{ sq. ft (rounded up)} \end{aligned}$$

$$\begin{aligned} \text{Hips and Ridge Before Waste and Salvage} \\ &= (\text{Hips Length} + \text{Ridge Length}) \times 1 \text{ sq. ft./ft} \\ &= (65 \text{ ft} + 22 \text{ ft}) \times 1 \text{ sq. ft/ft} = 87 \text{ sq. ft} \end{aligned}$$

$$\text{Tabs salvaged at hips} = 65 \text{ ft} \times 0.5 \text{ sq. ft./ft} = 33 \text{ sq. ft}$$

$$\begin{aligned} \text{Allowance} &= \text{Waste at Hips and Ridge} \\ &= \text{Required Hip \& Ridge Shingles} - \text{Salvage} \\ &= 87 \text{ sq. ft} - 33 \text{ sq. ft} = 54 \text{ sq. ft} \end{aligned}$$

$$\begin{aligned} \text{Total Shingle Requirement} \\ &= \text{starter course} + \text{roof area} + \text{cutting waste} + \text{Allowance} \\ &= 132 \text{ ft starter course} + 1048 \text{ sq. ft} + 46 \text{ sq. ft} + 54 \text{ sq. ft} \\ &= 1148 \text{ sq. ft} \div 100 \text{ sq. ft/ square} + 132 \text{ ft starter course} \\ &= 12 \text{ squares} \times 3 \text{ bundles/square} + 132 \text{ ft starter course} \\ &= 36 \text{ bundles} + 132 \text{ ft starter course} \end{aligned}$$

HIP ROOF WITH VALLEYS (SIMPLE)

The roof depicted in *Figure 3-13* has six hips and two valleys with a 6/12 slope. We assume an open valley construction. This example demonstrates the use of waste factors.

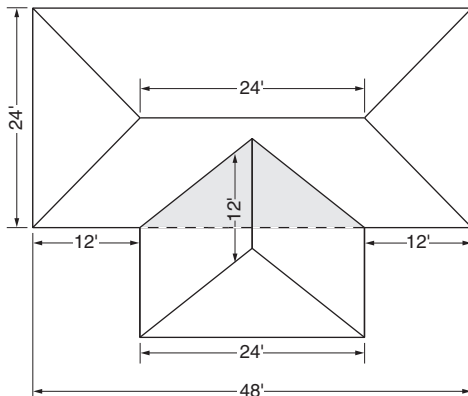

Figure 3-13

The roof area, since the slope is 6 inches/ft, is

$$\text{Roof Area} = [\text{main roof plan view area} - \text{ell triangle roof plan-view area} + \text{ell roof plan-view area}] \times \text{slope factor.}$$

A NOTE FOR THE GEOMETRICALLY CHALLENGED: This is an unusual roof because all slopes are equal and they are all hip roofs. Sometimes you get lucky. When this is the case the underlying triangle on the main roof is equal to the overlaying ell triangle. The result being we can ignore the separate calculation of the ell triangles because they cancel each other.

$$\begin{aligned} \text{Roof Area} &= \text{plan view area} \times \text{slope factor (6/12 in/ft)} \\ &= (48 \text{ ft.} \times 24 \text{ ft.} + 24 \text{ ft.} \times 12 \text{ ft.}) \times 1.118 \\ &= 1609.92 \text{ sq. ft} \end{aligned}$$

To calculate the starter course, find the total length of the eaves.

$$\text{Total length of eaves} = 2 \times 48 \text{ ft} + 2 \times 24 \text{ ft} + 2 \times 12 \text{ ft} = 168 \text{ ft}$$

So the starter course is a 168-ft long starter course.

$$\begin{aligned} \text{Length of a hip} &= \text{length of a valley} \\ &= 12 \text{ ft} \times \text{Table 2 hip/valley factor (6 in/ft)} \\ &= 12 \text{ ft} \times 1.5 = 18 \text{ ft} \end{aligned}$$

$$\begin{aligned} \text{Cutting Waste (hips \& valleys)} \\ &= \text{hips waste} + \text{valleys waste} \\ &= 6 \times 18 \text{ ft} \times \text{Table 3 hip waste factor} + 2 \times 18 \text{ ft} \\ &\quad \times \text{Table 3 valley waste factor} \\ &= 108 \text{ ft} \times 0.7 \text{ sq. ft/ft} + 36 \text{ ft} \times 1.5 \text{ sq. ft/ft} \\ &= 130 \text{ sq. ft} \end{aligned}$$

$$\text{Ridge length} = 24 \text{ ft} + 12 \text{ ft} = 36 \text{ ft}$$

$$\text{Hips length} = 6 \times 18 \text{ ft} = 108 \text{ ft}$$

$$\begin{aligned} \text{Shingles required for hips \& ridge} \\ &= \text{Length of hips and ridge} \times 1 \text{ sq. ft/ft} \\ &= (6 \times 18 \text{ ft} + 36 \text{ ft}) \times 1 \text{ sq. ft/ft} \\ &= (108 \text{ ft} + 36 \text{ ft}) \times 1 \text{ sq. ft/ft} = 144 \text{ sq. ft} \end{aligned}$$

$$\text{Salvage at hips} = 108 \text{ ft} \times 0.5 \text{ sq. ft/ft (Table 3)} = 54 \text{ sq. ft}$$

$$\text{Salvage at open valleys} = 36 \text{ ft} \times 2.0 \text{ sq. ft/ft (Table 3)} = 72 \text{ sq. ft}$$

$$\begin{aligned} \text{Total Shingles Required} \\ &= \text{roof area} + \text{cutting waste} + \text{hips \& ridge shingles} \\ &\quad - \text{salvage} + \text{starter course} \\ &= 1609.92 \text{ sq. ft} + 130 \text{ sq. ft} + 144 \text{ sq. ft} - (54 + 72) \\ &\quad \text{sq. ft} + \frac{168}{3} \text{ starter shingles} \\ &= 1758 \text{ sq. ft} + 56 \text{ starter shingles} \\ &= 18 \text{ squares} + 56 \text{ starter shingles} \end{aligned}$$

ESTIMATING WORKSHEET SAMPLES

Below are two worksheet samples. On the next page is a blank worksheet including all four Tables provided in this chapter. These worksheets are adaptable to computer spreadsheets. The "Rule of Thumb" method is shown below the tables. The results are about the same in these cases when rounded up. (*The percentages used are extrapolated from Table 4 as appropriate to the actual square feet.)

CONVENTIONAL HIP ROOF								
Notes	length	width	sub total	factor	sub total	extension	Square Ft.	Squares
Roof area	44	22	968	1.083	1048.344		1048.344	10.48344
Starter course <i>lineal feet</i>	44	22	66	2	132			0
Hip shingles <i>1 sq/sq ft.</i>	11			1.474	16.214	4	64.856	0.64856
Ridge shingles	22					1	22	0.22
Hip waste	16.214			0.7	11.3498	4	45.3992	0.453992
Valley waste <i>none</i>								
Hip salvage	16.214			-0.5	-8.107	4	-32.428	-0.32428
Total							1148.1712	11.481712
Order 12 sqs. plus 44 (132/3) starter shingles								

Improved Rule of Thumb Method	sq ft	hip roof factor	adj sq/ft	Order
<i>(see page 26)</i>	1048.344	12%* = 126 sq.ft.	1174.344	12 sqs. (rounded up)

HIP ROOF WITH ELL (VALLEYS)								
Notes	length	width	sub total	factor	sub total	extension	Square Ft.	Squares
Roof area <i>Main</i>	48	24	1152	1.118			1287.94	12.88
<i>Ell</i>	24	12	288	1.118			321.98	3.22
Starter course <i>(Lineal Ft.)</i>	168							0
Hip shingles <i>6" rise</i>	12			1.5	18	6	108	1.08
Ridge shingles <i>Main</i>	24						24	0.24
<i>Ell</i>	12						12	0.12
Hip waste	18			0.7	12.6	6	75.6	.76
Valley waste	18			1.5	27	2	54	0.54
Hip salvage	18			-0.5	-9	6	-54	-0.54
Valley salvage	18			-2.0	-36	2	-72	-0.72
Total							1757.52	17.58
Order 18 sqs. plus 56 (168/3) starters								

Improved Rule of Thumb Method	sq ft	hip roof factor	adj sq/ft	Order
<i>(see page 26)</i>	1609.92	10%* = 161 sq.ft.	1771	18 sqs. (rounded up)

Here Are Some Tips...

Teddy Payne of Petersburg, VA suggests carrying an instant camera to all estimate/measuring appointments. It comes in handy when trying to explain to customers existing problems, as well as potential problems. Customers can actually see what you are trying to explain to them and what needs to be done.

A simplified method for calculating the area and waste for a hip roof:

Consider a hip roof section with the following dimensions: 40' eave, 20' ridge, and 30' from eave to ridge. The average of the eave and ridge is 30 ft. (40 ft plus 20 ft divided by 2 equals 30 ft.) The area for this hip section is then 30 ft. times 30 ft or 900 square ft. (9 squares.) For waste we add one shingle for each three feet of hip. The hip length is the square root of 1000 (100 plus 900) or approximately 32 ft. Therefore we add 32/3rds (10.67) shingles for each hip. Thanks to Scott Wilson from Westerville, OH.

ESTIMATING WORKSHEET

Notes	length	width	sub total	factor	sub total	extension	Square Ft.	Squares
Roof area								
Starter course (L/Ft.)								
Hip shingles								
Ridge shingles								
Hip waste								
Valley waste								
Hip salvage								
Valley salvage								
Total								
Order								

Table 1

Rise inches/ft	Slope factor
4	1.054
5	1.083
6	1.118
7	1.157
8	1.202
9	1.250
10	1.302
11	1.356
12	1.414

Table 2

Rise inches/ft	Hip/Valley factor
4	1.452
5	1.474
6	1.500
7	1.524
8	1.564
9	1.600
10	1.642
11	1.684
12	1.732

Table 3

Waste and salvage factors for 3-tab shingles (sq. ft/ft)

Type	Waste Factor	Salvage factor
Rake	0.3	1.0
Hip	0.7	0.5
Open Valley	1.5	2.0
Closed Valley	2.2	1.0
Woven Valley	3.0	0

Table 4

Approximate percent to use for waste

Area of roof (sq. ft)	Gable Roof percent	Hip Roof percent
600	8	17
1200	6	13
1500	5	11
2000	4	9
3200	3	8