

Ventilation Standards and Systems

7

YOUR OBJECTIVE:

To learn how different attic ventilation systems are designed and which designs are the most effective. Also, to understand how ventilation affects the roofing system, as well as the entire house.

WHAT VENTILATION DOES

Ventilation is a system of intake and exhaust that creates a flow of air. Effective attic ventilation provides year-round benefits, creating cooler attics in the summer and drier attics in the winter, protecting against damage to materials and structure, helping to reduce energy consumption and helping to prevent ice dams.

With poor ventilation, summer sunshine can cause a terrific build-up of heat in the attic space. In a home with poor ventilation, the heat in the attic may eventually reach 140°F on a 90° day. If the unventilated attic is heavily insulated, that heat will stay there much of the night, perhaps slowly migrating to the home's interior. An overheated attic, combined with moisture, can also be damaging to roof decking and roofing shingles, causing them to distort and deteriorate prematurely.

In the winter, again in a house with poor ventilation, moist, warm air from the lower portions of the home will tend to rise through the ceiling area into the attic, especially through bypasses where electrical and plumbing fixtures are installed. In a cold attic, the warm, moist air condenses on the cold surfaces of the rafters, the nails and other metal, and the attic side of the deck. This water can create several problems.

First, the condensation can swell the deck, causing waviness and buckling of both the deck and the shingles. Second, the water can rot the roof deck, destroying its ability to carry loads (like a roofing crew) and its nail-holding capability. Third, severe condensation can drip onto the insulation, reducing its effectiveness and possibly seeping through to the ceiling below.

Another winter problem caused by poor ventilation is the formation of ice dams. Ice dams form in cooler climates in winter when heat collects in a poorly ventilated and/or inadequately insulated attic. Built-up attic heat combines with the sun's warmth to melt snow

on the roof, even though outside temperatures may be below freezing. Then the flow of melting snow refreezes at the eaves and gutters. This freeze – thaw cycle can result in a pool of water that can back up under roof shingles and behind fascia boards, soaking roof decking and wall sheathing, damaging exterior and interior walls, peeling paint and ruining ceilings. Soaked lumber and building materials lead to secondary problems: wood rot, bug infestation, mold and degradation of structural integrity.

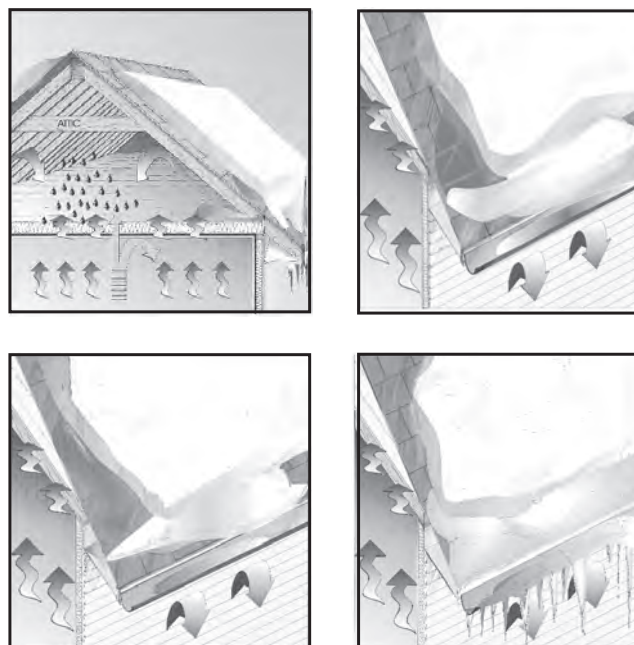

Figure 7-1

In a four-phase cycle of freeze and thaw, snow begins to melt when heat in the attic warms the underside of the roof deck and causes snow to melt and run down the roof. The melting snow refreezes at gutters and soffits. Pools of water and ice back up and soak decking and wall sheathing, then refreeze again to further damage all building materials (Figure 7-1).

Good ventilation will move the hot air next to the roof deck out of the attic in the summer, and it will dilute and remove the moist air in the winter, before it can cause damage. Also, proper ventilation, in combination with sufficient insulation, helps keep a more uniform temperature on the underside of the deck in the winter, and that can eliminate one of the principal causes of ice dam formation.

WHAT ARE THE BENEFITS OF ATTIC VENTILATION?

An effective attic ventilation system provides year-round benefits. During warmer months, ventilation helps keep attics cool. During colder months, ventilation reduces moisture to help keep attics dry. It also helps prevent ice dams. This results in:

- added comfort inside the house
- protection against damage to roof materials and structure
- reduced energy consumption throughout the year

VENTILATION DURING WARM WEATHER

You appreciate the effects of ventilation when you look at the temperatures involved. These are typical temperatures for a home with no attic ventilation, on a sunny day, with an outdoor temperature of 90°F (32°C):

- Temperature at roof sheath: as high as 170°F (77°C).
- Temperature at attic floor: up to 140°F (60°C).
- Temperature in rooms directly beneath attic: uncomfortable.

An unventilated — or inadequately ventilated — attic seldom loses enough heat overnight to compensate for the heat gained during the day. Ironically, the effect is magnified in modern homes with heavier insulation. Over time excess attic heat can cause premature failure in some shingles.

HOW VENTILATION HELPS SOLVE ATTIC HEAT PROBLEMS

Ventilation can't eliminate the transfer of heat from roof to attic, but it can minimize its effect. To do that, a well-designed system must provide a uniform flow of air along the underside of the roof sheathing. That steady flow of air carries heat out of the attic before it can radiate to the attic floor.

It's critical that this airflow is distributed uniformly. That means intake and exhaust vents must be balanced — for both position and airflow capacities. Otherwise, "hot spots" can develop under roof sheathing, drastically reducing the efficiency and effectiveness of whatever ventilation is installed.

VENTILATION DURING COLD WEATHER

When temperatures plunge, you might think the movement of heated air would no longer cause problems in attics. But that's not true. With seasonal changes, the conditions just reverse. Heat doesn't travel from an attic into the living quarters. Instead, heated indoor air travels from the home into the attic — along with moisture.

Figure 7-2 illustrates how this process of moisture transfer takes place. Furnace-warmed air circulates through the house, picking up water vapor generated by activities such as cooking, bathing, and the washing of clothes and dishes. The average family of four generates between 2-4 gallons a day through such activities. The use of humidifiers, common in many homes, provides an abundant and continual source of moisture.

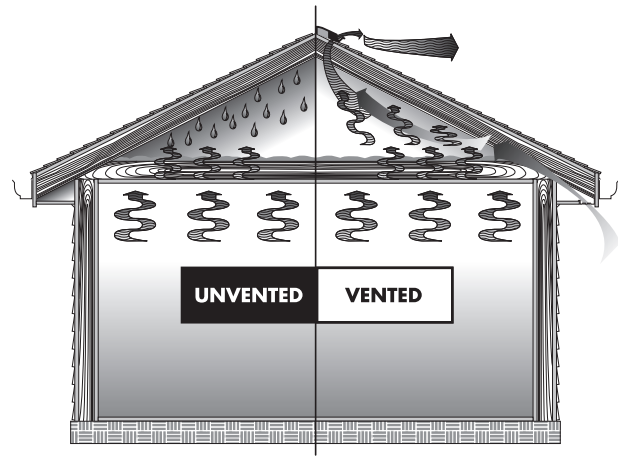

Figure 7-2: Unvented: Moisture rising up through the house condenses in the attic, causing damage to studs, insulation, and other materials. Vented: A vented attic allows moisture to escape.

The problem is especially acute in homes with electric heating. Most of these homes were built since the mid-1970s, using advanced insulation materials and methods. As a result, most are "tight," allowing minimal infiltration of outside air. In addition, electric heat sources do not require air for combustion, so another common source of outdoor air has been eliminated. The positive side of these super-insulated homes is, of course, the greater energy efficiency. But because cooler, drier outdoor air is kept out, the indoor air holds greater amounts of moisture.

The warm, moist air from the living quarters moves toward the attic, where the air is cooler and drier. That moist air is drawn to the attic in two ways:

- **vapor diffusion** – water vapor naturally travels from high-humidity conditions to low-humidity conditions. The force of vapor diffusion is so great that moisture even travels through building materials such as sheet rock. Even vapor barriers/retarders, for all their effectiveness, cannot totally stop this process.
- **air movement** – through openings such as recessed ceiling boxes and attic entries cut into a vapor barrier.

Troubles start when moist air hits cooler rafters, trusses and roof sheathing. The moisture condenses as water droplets or frost. Eventually, the condensation drips on the insulation below. If too much water soaks into the insulation, its volume can be compressed and its effectiveness reduced.

The structural elements of the house absorb some moisture, leading to wood rot and the deterioration of roofing materials. Moisture is likely to soak into the attic floor and eventually into ceiling materials in the rooms below.

HOW VENTILATION HELPS SOLVE ATTIC MOISTURE PROBLEMS AND ICE DAMS

Although the problems of heat and moisture accumulation in the attic have different causes, they share a common solution: a high-efficiency ventilation system. In warmer months, a ventilation system exhausts hot air from an attic; in the colder months, it exchanges warm, moist air with cooler, drier air.

Winter creates a special attic ventilation problem in areas where snowfall and cold temperatures are common occurrences. The problem begins with the formation of ice dams which prevent melt water from running off a roof.

Ice dams can form when:

- **Warm air accumulates in the attic.** Normally, the pocket of warm air in the upper portion of an attic won't result in problems — unless the following conditions occur as well:
- **Lower areas of the roof remain cold.** Especially near the eave, where temperatures may not be much higher than the ambient outdoor air. If the outdoor temperature is well below freezing, conditions are favorable for the formation of an ice dam.
- **A heavy snow cover accumulates on the roof.** Snow provides the necessary moisture and it also acts as a layer of insulation, preventing heat loss through the roof sheathing. As a result, attic temperatures are typically warmer than they are on days when the roof is free of snow.

Under these conditions, ice dams form quickly. Heat high in the attic causes snow to melt near the roof peak. The water from the melting snow flows toward the eave area, where colder roof temperatures allow it to freeze. If conditions persist over several days, this refreezing of snowmelt can form an ice dam.

The weight of a falling ice dam can damage gutters, fascia or shrubbery below. Roof damage occurs when the water pooling against the dam begins to back-up under shingles. The shingles get damaged or destroyed. Far more serious, however, is the damage caused at the plateline area. Insulation can be soaked, reducing its effectiveness. Plus, water can infiltrate into both exterior and interior walls, leading to structural damage. At the very least, mold spores and mildew can form, creating unpleasant odors and poor indoor air quality.

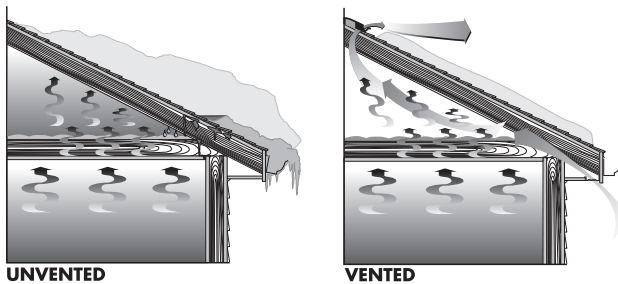

Figure 7-3: Unvented: Heat entering attic from the home melts the snow on the roof and forms destructive ice dams. Vented: Heat is vented out of the attic creating a cold roof.

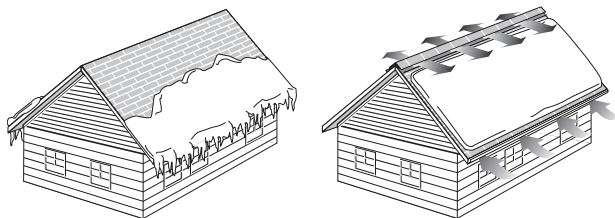

Figure 7-4: (Left) Ice dams, besides being unsightly, are destructive. (Right) Vented attic with even snow distribution is much more desirable.

No amount of insulation, if used alone, can eliminate the formation of ice dams. An efficient attic ventilation system must be part of any solution.

A properly designed ventilation system creates a “cold roof” — a condition where the roof temperature is equalized from top to bottom. An equalized roof temperature helps eliminate the conditions that lead to the formation of ice dams.

Ventilation alone isn't a complete solution either. Ventilation must be used with a waterproofing shingle underlayment and insulation. (Note: It's difficult to say precisely how much insulation will be required. Many factors, from house design to its orientation to the weather, enter into the equation. A good rule of thumb, however, is to provide at least 10 to 12 inches of insulation. That's the equivalent to an R-value of 38.)

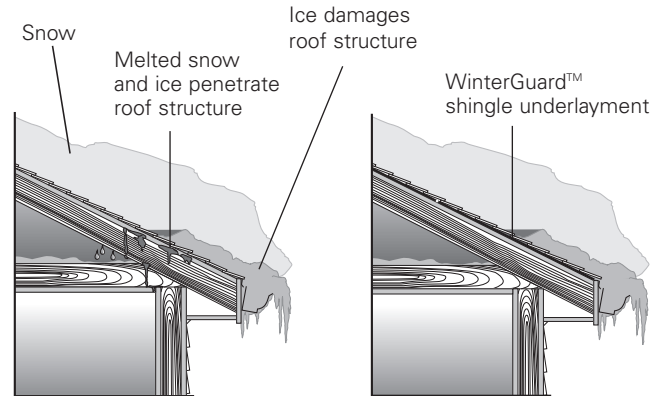

Figure 7-5: (Left) Water can penetrate to an unprotected roof sheath causing the roof sheath to rot. (Right) WinterGuard is a waterproofing shingle underlayment that prevents water from penetrating to the roof sheath.



Figure 7-6: The dark shaded areas are the places that WinterGuard helps protect from the melting water coming off the ice dam.

A DEFENSE AGAINST ICE DAMS

To reduce the possibility of ice dams, use a three-step approach:

1. **Install adequate attic ventilation.** The most effective way to equalize temperatures is to create a “cold roof.” One of the most efficient and cost effective systems uses ridge vents and evenly positioned intake vents to distribute airflow from peak to eave.
2. **Install adequate attic insulation.** Attic insulation serves two purposes:

- it reduces heat loss, which is a key factor contributing to the creation of ice dams
- adequate attic insulation diminishes the energy impact of having cold air flowing through the attic.

Be sure there is adequate insulation around electrical fixtures, and wiring and plumbing chases. These areas often contribute to significant heat loss. Check existing insulation for water damage and for areas compressed by foot traffic or stored objects. Finally, make certain existing insulation meets today's R-value requirements.

3. **Specify waterproofing shingle underlayment (WSU) where possible.** A WSU barrier can minimize or eliminate water infiltration into the building structure. WSU must be installed along the eaves and up the roof at least two feet beyond the interior wall line. Many contractors say more is always better. Closed valleys should be lined with a 36" wide piece of WSU.

HOW VENTILATION WORKS

"Ventilate" comes from the Latin word for "to fan," the action of causing air to move. And that's exactly how ventilation works: It provides the conditions that allow air to move. There are many types of attic ventilation systems in use today. Some systems use all natural forces to move the air, such as the wind and "thermal convection" (rising warm air). Other systems use mechanical fans to move the air. And still other systems use some combination of natural and mechanical forces.

Efficient ventilation requires a very specific type of air movement to provide year-round benefits.

A flow of air must be established to produce air changes — a steady, high volume of air movement. That means the system components must be correctly sized and positioned to provide constant air flow, moving in a constant direction.

We can create air movement in one of two ways: natural ventilation or mechanical ventilation. Two key forces create natural air movement: thermal effect and wind. Mechanical ventilation relies on a power source such as electricity.

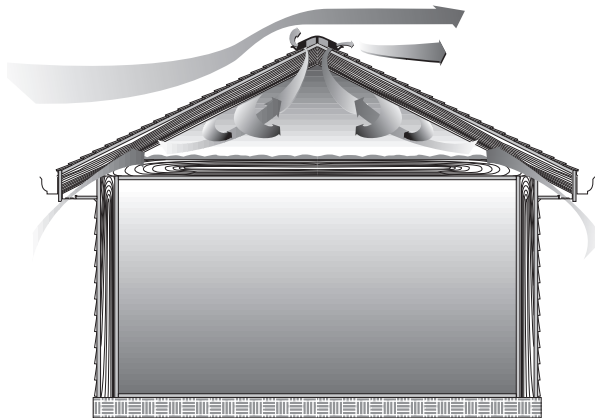
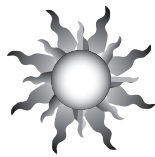

Figure 7-7: Thermal Flow (effect whereby cooler air falls, warmer air rises) and Natural Flow (effect due to wind) come together to ventilate an attic.

THERMAL EFFECT

Thermal effect is the inherent property of warm air to rise. A well-designed system takes advantage of that movement in two ways:

- **Exhaust vents at or near the ridge since warm air rises.** That placement allows the hottest air to be removed from the attic most efficiently.
- **Thermal effect creates a natural circulation of air, because as warm air rises, cooler air falls.** A well-designed system assists this momentum by placing intake vents at the lowest point in the attic, typically in the soffit or near the roof's edge. The cooler air entering these vents speeds this circulation of air.

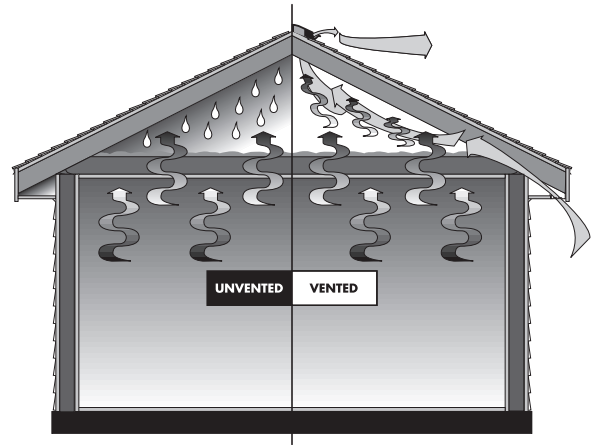

Figure 7-8: Attic ventilated by thermal effect.

WIND

By itself, however, thermal effect cannot create the high volume of air movement needed for effective ventilation. That's why the influence of wind is the key element in designing a non-powered ventilation system. You want to make the wind work to your advantage.

Here's how wind force affects ventilation. It isn't the velocity of the wind by itself that causes air to move through an attic. Instead, it's the wind's speed as it moves against and over a home's exterior surfaces. A wind-driven flow of air creates areas of high and low air pressure (see Figure 7-9). High pressure forces air into the attic, while low pressure pulls air out.

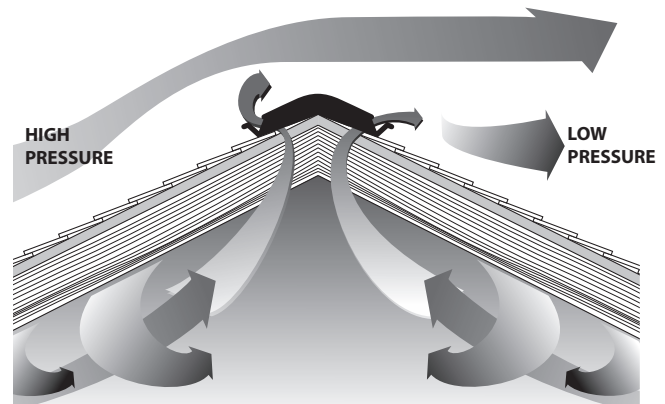

Figure 7-9: Wind passing over the baffled ShingleVent® II creates low pressure at the vent's opening, which causes air to be "lifted" or pulled out.

HOW TO PUT THESE NATURAL FORCES TO WORK

A properly designed ventilation system requires balance, which is achieved in two ways:

1. Airflow capacity must be balanced between intake and exhaust vents.

In general, the net free area of intake venting should be equal to or greater than the net free area of exhaust venting. (Note: Net free area means the total unobstructed area through which air can enter or exit a vent, measured in square inches.)

2. Intake and exhaust vents must be positioned to create a proper high-low balance.

That balance is achieved when: Half the vent area must be high in the attic (exhaust), with the other half low in the attic (intake). Without that balance, the area of effective ventilation is limited to the lesser of the two vent areas. For example, if 75 percent of the venting is high and 25 percent low, ventilation is limited to the air moving through the lower vents. For maximum efficiency, the net free area of the intake vents should be equal to or greater than the net free area of exhaust vents.

Proper placement of exhaust/intake vents assures a continuous flow of air, moving in the desired direction.

In planning the location of intake and exhaust vents, two factors must be considered:

1. Intake and exhaust vents must be positioned so they assure continuous airflow along the underside of the roof sheathing.
2. Intake vents must be located so there is little possibility of rain or snow infiltration. Conventional intake products require installation in the soffit. However, there are other intake products that allow roof-top installation.

Note: To assure optimum performance of intake vents, you must make certain the area above the intake opening isn't blocked by dirt, building debris or attic insulation.

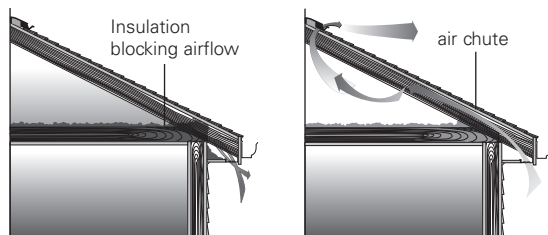

Figure 7-10: (Left) Insulation should not be installed over the soffit/undereave intake area or proper inflow to the attic will be impeded. (Right) An unblocked vent allows a passage for air to move through the attic.

CATHEDRAL OR VAULTED CEILINGS: Warm air which moves from the inside of the house to the roof might be moist because of a furnace humidifier, a wet basement, a wet crawl space, or some other moisture source. This can be the cause of serious sheathing deterioration in cathedral ceilings if they are not protected by an effective vapor barrier. Sometimes a vapor barrier is not enough. Therefore, the addition of a ridge vent and intake vent system, with air spaces (e.g., air chutes) of at least 1" (more on roofs with lower slopes) positioned beneath the sheathing, above the insulation is recommended.

However, if ridge ventilation is used on a cathedral ceiling roof without balanced intake ventilation, the problem can be made worse by pulling moist air from the living area upward, where it then saturates the wood and promotes mold growth on the sheathing. If deteriorated decking is found above a cathedral ceiling, do not replace the decking without addressing the root of the problem by installing proper ventilation and by installing an effective vapor barrier. You should be aware that the best clearance for air spaces has not been determined. Some literature recommends 1 1/2", but clearances of 3/4" and as much as 3" have also been recommended. Greater clearance will be the safer choice.

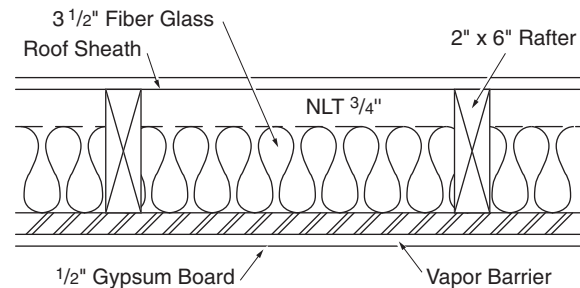

Figure 7-11: Ventilating cathedral ceilings (illustration is drawn horizontally for convenience).

HIP ROOFS: Venting options for hip roofs are:

- ◆ Shingle-over ridge vents designed specifically for the diagonal hips of a roof balanced with intake vents around the perimeter of the house.
- ◆ Venting with a short ridge vent and four sides of soffit vents. To satisfy code requirements, measure the length of both the ridge and soffit vents. You'll probably achieve sufficient ventilation if 40 percent of the vent area is at the ridge and you maximize venting in the soffit.
- ◆ Power vents located at the upper portion of the roof with adequate intake venting at the eaves.

ROOFS WITH UNUSUAL SHAPES: Roof shapes such as "L," "T," cone and octagonal, have an impact on the type of venting required for proper performance. Continuous ridge vents in combination with intake vents can be used effectively with "L" or "T" shaped roofs, if installed properly. Vents should run across both the long and short ridges as long as all attic areas are open to each other. If ridge heights vary by more than 3 feet and the attics are connected, vents should be placed only along the highest ridge. This design prevents snow infiltration and eliminates a potential "short-circuiting" problem where vented ridges at various heights limit the air flow to that level and compromise the "whole house" effectiveness of the ridge intake vent arrangement. Or, use plywood to separate the attics and then it is allowable to install ridge vents on the varying height ridges.

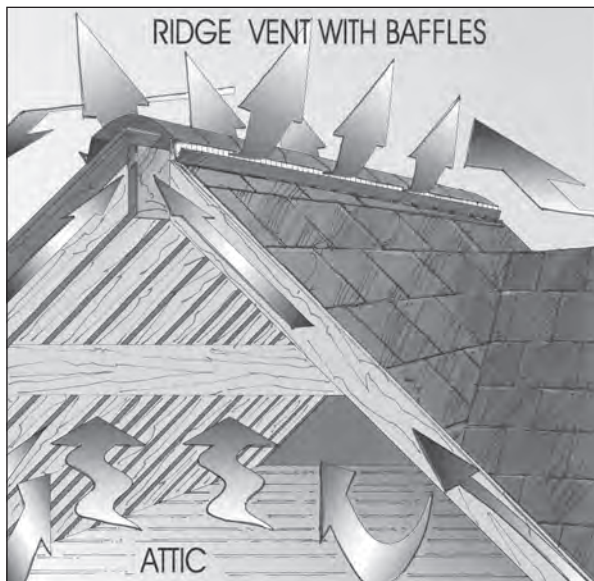

Figure 7-12: In L- or T-shaped roofs, vents should run across both the long and short ridges as long as areas are open to each other. If roof heights vary by more than 3 feet, vents should be placed only along the highest ridge or separate the attics.

METAL CONSTRUCTION MATERIALS CAN AFFECT ATTIC VENTILATION

As a better conductor than wood, metal framing and metal duct work in the attic can speed condensation, which in turn breeds problems of mold, rot and poor indoor air quality, to name a few. Metal framing, therefore, may increase the need for ventilation, insulation, vapor retarders and other materials.

DETERMINING ATTIC VENTILATION REQUIREMENTS

Before the mid-1970s, few people thought about establishing precise requirements for attic ventilation. Homes were not built as air tight as they are today. If a home had any attic ventilation at all, it usually consisted of some undereave vents. In some warmer areas of the country, one or more louvers might supplement those vents (the purpose being, “to catch the breeze”). In especially warm regions, an attic fan might be installed (even though there might not be sufficient intake venting to assure proper functioning).

Even if designers and specifiers had wanted to calculate specific requirements for temperature or moisture reduction, they had little research-based information to guide them.

The Federal Housing Administration tried to close that information gap with minimum property standards for buildings with one or two living units. Since then, other standards have been developed. An example of current minimum requirements for ventilation comes from the 2012 International Residential Code (IRC) Section R806:

- ★ **R806.1 Ventilation required.** Enclosed attics and enclosed rafter spaces formed where ceilings are applied to the underside of roof rafters shall have cross ventilation for each separate space by ventilating openings protected against the entrance of rain and snow...
- ★ **R806.2 Minimum area.** The minimum net free ventilating area shall be 1/150 of the area of the vented space.
 - Exception:** The minimum net free ventilating area shall be 1/300 of the vented space provided one or more of the following conditions are met:
 1. In Climate Zones 6, 7 and 8, a Class I or II vapor retarder is installed on the warm-in-winter side of the ceiling.
 2. At least 40 percent and not more than 50 percent of the required ventilation area is provided by ventilators located in the upper portion of the attic or rafter space...with the balance of the required ventilation provided by eave or cornice vents.
- ★ **R806.3 Vent and insulation clearance.** Where eave or cornice vents are installed, insulation shall not block the free flow of air. A minimum of a 1-inch (25 mm) space shall be provided between the insulation and the roof sheathing at the location of the vent.
- ★ **R806.4 Installation and weather protection.** Ventilators shall be installed in accordance with manufacturer's installation instructions.

If you want to install an effective, year-round ventilation system use the 1/150 ratio. This ratio takes into account that today's homes are built with – or remodeled with – materials (doors, insulation, windows, etc.) that are more energy efficient. Consequently, these homes are more airtight and need more attic ventilation.

VENTILATION STANDARDS AND SHINGLE WARRANTIES

STANDARDS FOR VENTILATION: The Housing and Urban Development agency, model building codes and ASHRAE have set standards for attic ventilation. Most shingle manufacturers have adopted these standards as minimum acceptable ventilation requirements in their shingle warranties. The standards require a minimum of 1 square foot of net free ventilation area for every 150 square feet of attic floor space. However, if approximately half of the open ventilation area is in the upper portion of the roof, such as at the ridge, and half is in the lower area, such as at the soffits or eaves, the standard reduces to 1 square foot of net free ventilation for every 300 square feet of attic floor space. A balanced system allows a less restricted, even flow of air through the attic space. When in-and-out ventilation cannot be equally balanced, research indicates that it is better to have somewhat more ventilation area at the lower part of the roof.

WARRANTIES: Shingle manufacturers require that roof systems in which its shingles are installed meet HUD or local building code standards for ventilation. If not, the shingle warranty terms may be void in whole or in part.

GENERAL VENTILATION REQUIREMENTS FOR CERTAINTEED SHINGLE WARRANTY COMPLIANCE

- ◆ If full intake to ridge ventilation is installed, the ratio of Net Free Ventilation Area (NFVA)/attic floor space must be at least 1/300.
- ◆ In most other cases the ratio required is 1/150.
- ◆ If the 1/150 cannot be obtained, the shingle roof warranty for any CertainTeed asphalt composition shingle will be reduced to a maximum of 10 years without SureStart protection, with respect to shingle problems related to the absence of adequate ventilation (see warranty for details).

CALCULATING REQUIREMENTS FOR AN EFFICIENT FIXED VENT SYSTEM

If you want to install an effective, year-round ventilation system follow the steps below which are based on the 1/150 ratio. This ratio takes into account that today's homes are built with – or remodeled with – materials (doors, windows, insulation, etc.) that are much more air-tight than ever before and need more ventilation.

Note: The following process is used to calculate requirements for non-powered ventilation systems.

1. Determine the square footage of attic area to be ventilated.

Multiply the length of the attic (in feet) by its width.

Example: For this and the following calculations, we'll assume a project involving a home that has a 40' by 25' attic area.

Calculation:

$$40' \times 25' = 1,000 \text{ sq. ft. of attic area.}$$

2. Determine the total net free area required.

Once the attic square footage is known, divide by 150 (for the 1/150 ratio). That determines the total amount of net free area needed to properly ventilate the attic.

Calculation:

$$1,000 \text{ sq. ft.} \div 150 = 6.6 \text{ sq. ft. of total net free area.}$$

3. Determine the amount of intake and exhaust (low and high) net free area required.

For optimum performance, the attic ventilation system must be balanced with intake and exhaust vents. This is a simple calculation: just divide the answer from Step 2 by 2.

Calculation:

$$6.6 \div 2 = 3.3 \text{ sq. ft. of intake net free area and 3.3 sq. ft. of exhaust net free area.}$$

4. Convert to square inches.

The net free area specifications for attic ventilation products are listed in square inches. Therefore, let's convert our calculation in Step 3 from square feet to square inches. To do this simply multiply by 144 (which is the number of square inches in a square foot.)

Calculation:

$$3.3 \text{ sq. ft.} \times 144 = 475 \text{ sq. in. of intake net free area and 475 sq. in. of exhaust net free area.}$$

5. Determine the number of units of exhaust and intake venting you'll require.

To make these calculations you'll need to know the net free area specifications of the exhaust and intake vents being specified/installed for the project. As a guide, the Table on page 77 lists the net free area specifications, in square inches, of Air Vent intake and exhaust vents.

To perform the calculations, divide the net free area requirement from Step 4 by the appropriate figure from the Net Free Area Table. For our example, we will use the figures for Air Vent's ShingleVent® II ridge vents and undereave vents.

Calculation:

(for 4-foot length of ridge vent)

$$475 \text{ sq. in.} \div 72 = 6.6 \text{ pieces of vent (or seven 4-foot lengths of ridge vent)}$$

(for 16" x 8" undereave vent)

$$475 \text{ sq. in.} \div 56 = 8.5 \text{ pieces of vent (or nine 16" x 8" vents)}$$

MEET MINIMUM CODE REQUIREMENTS

To determine how many square feet of NET FREE VENTILATION AREA (NFVA) you need for a balanced soffit to ridge vent system, use this formula:

$$\frac{\text{Sq. ft. of attic floor space}}{300} = \text{Sq. ft. of NFVA needed}$$

(NOTE: "300" will be changed to 150 for homes without balanced air flow.)

To determine how many linear feet of Air Vent Ridge Vent you need, use this formula:

$$1/2 \text{ NFVA needed} \times 144 \div 18 = \text{feet of ridge vent needed.}$$

To determine how many linear feet of AIR VENT CONTINUOUS SOFFIT VENTS you need, use this formula:

$$1/2 \text{ net-free area} \times 144 \div 9 = \text{feet of soffit vent needed.}$$

NOTE: soffit vents must be installed evenly along all soffits.

CALCULATING REQUIREMENTS FOR POWER ATTIC VENTILATORS

If you plan on installing a power fan, you can calculate intake and exhaust requirements using the following formulas:

1. Determine the fan capacity needed to provide about 10 to 12 air exchanges per hour.

The formula is: Attic square feet x 0.7 = CFM capacity

For example, using the same dimensions as the previous example:

Calculation:

$$1,000 \text{ sq. ft.} \times 0.7 = 700 \text{ CFM.}$$

Note: For roofs with a 7/12 to 10/12 roof pitch, you may want to add 20% more CFM; and for roofs 11/12 pitch and higher add 30% more CFM to handle the larger volume of attic space.

2. Determine the amount of intake venting required.

The formula is: CFM rating of fan ÷ 300 = square feet of intake ventilation needed.

Calculation:

$$700 \text{ CFM} \div 300 = 2.3 \text{ square feet.}$$

3. Convert to sq. in. by multiplying by 144 (which is the number of sq. inches in a sq. ft.).

The formula is: sq. ft. of intake ventilation net free area x 144" sq. in. of intake ventilation net free area needed.

Calculation:

$$2.3 \text{ sq. ft.} \times 144 = 331 \text{ square inches of net free intake area}$$

To find the number of intake vents required, use the Net Free Area Table as explained earlier in Step 5.

NET FREE AREA TABLE	
Type of Vent	Net Free Attic Vent Area (sq. in. — approximate) [†]
High Vents – Exhaust	
FilterVent® (8' length)	144
ShingleVent® II (4' length)	72
Hip Ridge™ Vent (4' length)	48
Roof louver	50
Wind turbine (12")	95
Rectangular gable vents	
12" x 12"	40
12" x 18"	59
14" x 24"	92
18" x 24"	119
24" x 30"	324
Low Vents – Intake	
16" x 8" undereave vent	56
16" x 6" undereave vent	42
16" x 4" undereave vent	28
Continuous soffit vent & vented drip edge: 8' length	72
Shingle-over intake The Edge™ Vent: 4' length	36
Perforated aluminum soffit: One square foot	14
Lanced aluminum soffit: One square foot	4-7

[†]Be sure to check specifications for individual products to determine actual net free vent area.

TYPES OF ATTIC VENTILATION PRODUCTS

In general, ventilation components can be divided into two main categories: intake vents and exhaust vents.

INTAKE VENTS

The best location for intake vents is in or near the roof eave or low at the roof's edge, placed on both sides of the roof.

Intake vents are available in many designs. In choosing the right unit for a particular job, you have to consider the structure of the home, the area where the units will be located and the net free area provided by each unit.

The most common types of intake venting are:

- Undereave vents, which are mounted in the soffit. Units vary in size from 16" x 8" to 16" x 4". Net free area varies according to unit size.
- Continuous soffit vents, which are also mounted in the soffit. These units vary in length, with the typical length being 96".
- Vented drip edge, which is used on homes without an eave area.
- The Edge Vent shingle-over intake which is a roof-top installed vent available in 4' lengths.

- Mini-louvers, which are typically used with other types of intake venting; they're too small by themselves to provide sufficient net free area of intake. In most applications, they're installed in an exterior wall to help eliminate moisture that collects in the wall cavity. To be effective, mini-louvers must be installed below the source of humidity (such as a bathroom or laundry area). That placement allows a flow of air to collect the humidity and carry it into the attic.
- Vented soffit panels, which are vinyl or aluminum soffits with vent openings already cut into the panels. Be sure to check the net free area of the panels to assure they provide enough ventilation to balance the system.

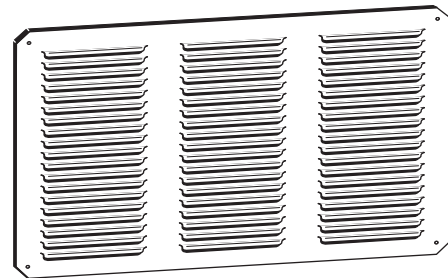

Figure 7-13: The undereave vent, an intake vent, allows needed air to enter the attic. It is located on the underside of the eave.

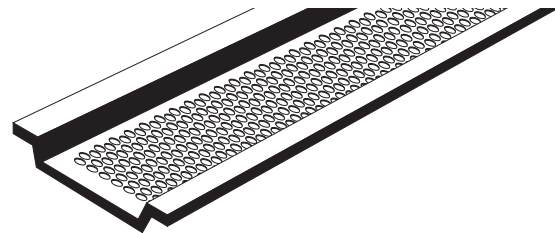

Figure 7-14: A continuous soffit vent takes in outside air and is located on the underside of the eave.

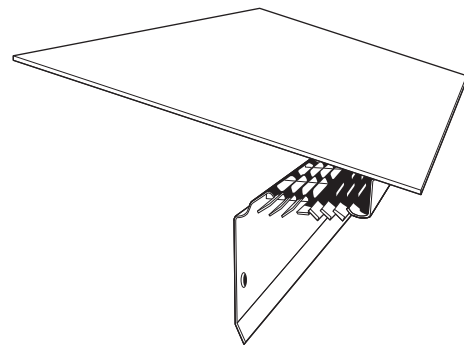

Figure 7-15A: For soffitless applications vented drip edge combines a drip edge with intake louvers.



Figure 7-15B: While conventional intake vents require installation in the soffit for maximum weather protection, the shingle-over intake vent The Edge Vent has been designed for roof-top installation and maximum weather protection.

Here's a Tip... When installing ridge vent with equal soffit ventilation, all other exhaust vents should be removed or blocked with plywood or plastic. Attic fans should also be removed and the decking replaced where the fan was installed. (Thanks to Vincent Hee of Oreland, Pennsylvania.)

EXHAUST VENTS

Exhaust vents are designed to permit an efficient, unobstructed out-flow of attic air. These units must be designed to prevent (or at least minimize) rain and snow infiltration. Exhaust vents must be used with intake vents to provide proper high/low balance and thus an adequate flow of air through an attic.

Exhaust vents are available in different designs:

Roof louvers

Roof louvers (also called roof pots) are installed as close to the roof ridge as possible to allow maximum release of moisture and overheated air. They are available in round, square and slant-back styles. Because they're installed near the ridge, they provide a continuous airflow along most of the underside of the roof sheathing. The airflow pattern isn't uniform, however, so for maximum effectiveness, vents should be spaced equally along the roof.

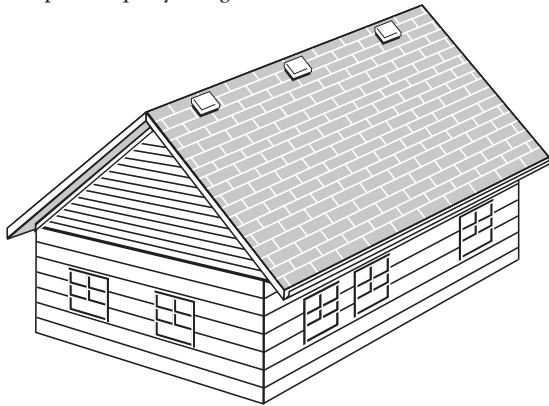

Figure 7-16: A roof louver is an exhaust vent located near the ridge.

Gable louvers

Gable louvers are typically installed in the gable ends of the house. Two types are available: rectangular and triangular. In most installations, a unit is placed at each gable end.



Figure 7-17: The gable-louver, an exhaust vent, allows unwanted air to flow out of the attic. These are located at the ends of the attic.

Note: Sometimes louvers are installed in opposite gable ends, without intake venting, in the mistaken assumption that a good "cross flow" of air can provide adequate ventilation. What typically happens, however, is illustrated in Figures 7-18 and 7-19. If wind direction is perpendicular to the ridge, the louvers act as both intake and exhaust vents, providing ventilation only in the areas near the vents. If the wind direction is parallel to the ridge, a cross flow of air is established, although the flow tends to dip toward the attic floor, leaving the hottest air still at the underside of the roof sheathing. Of course, if absolutely no intake venting can be installed at low points in the attic, a louver-only installation is preferable to no ventilation at all.

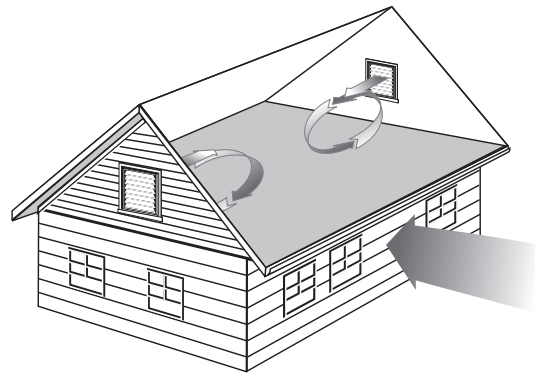

Figure 7-18: With wind blowing perpendicular to the ridge, the louvers act as both intake and exhaust vents.

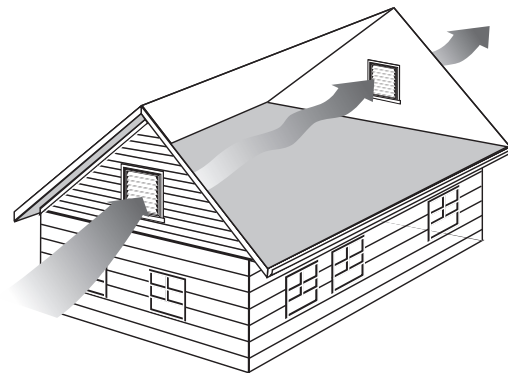

Figure 7-19: With wind blowing parallel to the ridge, airflow dips toward the attic floor leaving the hottest air still on the underside of the roof sheathing.

NEVER MIX TWO TYPES OF EXHAUST VENTS

When ridge and soffit ventilation is added to an attic with other vents in place, such as gable end vents, roof louvers, wind turbines or power fans, you must remove or block off the other ventilators. When installed properly, ridge and soffit systems draw air in the bottom (soffits) and out the top (ridge). Other open ventilator holes in the roof or gable will shortcut the low-to-high draft and diminish the ventilation effectiveness. It can also lead to weather infiltration.

RIDGE VENTS

Ridge vents offer unique advantages compared to other types of exhaust vents. Those advantages include:

- **Maximum efficiency.** The best ridge vents use an external baffle designed to draw heated air from an attic regardless of wind direction or force. Figure 7-20 shows how that happens.



Figure 7-20: A bafled FilterVent® creates an area of low pressure on both sides of the ridge vent. It literally lifts air out of the attic through both sides of the vent.

When wind direction is perpendicular to the ridge, it strikes the external baffle and jumps over the ridge. That movement creates a Bernoulli effect, causing low pressure to develop on both sides of the vent. When that happens, air from the attic is “lifted” out, in much the same way low pressure created above an airplane wing gives “lift” to the plane (refer also to Figure 7-9).

The same thing happens when the wind direction is parallel to the ridge. It moves up and over the ridge, creating a low pressure area.

In addition, when little wind force exists, ridge vents take full advantage of the thermal effect to maintain air circulation across the underside of the roof sheathing. Warm air rises to the ridge and exhausts through the vent. That allows a continuous flow of cooler air to enter at intake vents. Only ridge vents use thermal effect efficiently and effectively, because only ridge vents provide continuous and uniform air movement along the full length of a roof.

Note: For best results, intake venting should be divided equally along both sides of a structure.

- **Maximum air movement.** Ridge vents with an external baffle provide a higher volume of airflow per square foot of attic area than any other fixed non-powered vent system. That conclusion is based on a series of independent tests that measured — and compared — the volume of air movement provided by ridge vents and other fixed vent systems. Externally baffled ridge vents work better because they take advantage of two natural forces: the thermal effect (the fact that warm air rises) and low air pressure that is created as air is deflected by the baffle up and over the ridge vent to create an area of low pressure on both sides of the ridge vent (see Figure 7-9).
- **Uniform air movement.** Because ridge vents run the entire length of a roof, they provide a uniform flow of air along the underside of the roof sheathing. That air movement helps eliminate “hot spots” that can develop with other types of exhaust vents — even powered vents. No other exhaust vent provides this type of airflow pattern.

- **Maximum visual appeal.** Most ridge vents offer a low-profile design that minimizes its appearance on a roof. Shingle-over designs allow optimum blending with other roof materials.

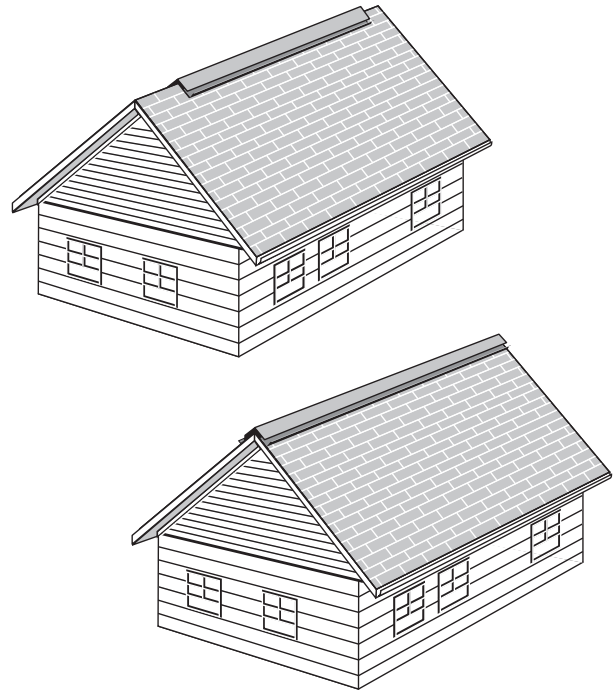

Figure 7-21: (Top) Ridge vent shorter than the ridge length presents an unattractive “broken” appearance. (Bottom) A ridge vent should extend all the way from one end of the roof to the other end of the roof for a smooth “unbroken” roof line.

It’s important to emphasize that the advantages listed above apply only to ridge vents that use an external baffle design. A series of independent tests has concluded that only an external baffle can direct the wind up and over the vent. That’s significant, because it’s that controlled flow of air that creates the area of low pressure that causes air to be drawn or pulled from an attic.

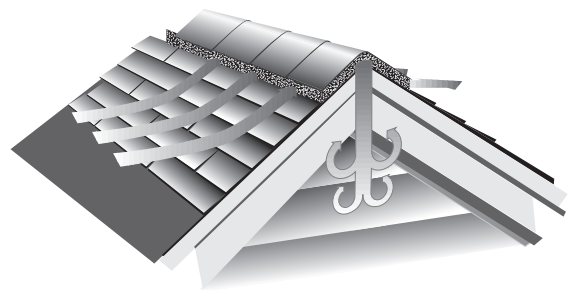

Figure 7-22: A roll vent with an internal baffle, or without any baffle at all, does not “pull” air from the attic through both sides of the vent.



Figure 7-23: An externally baffled vent “pulls” air from the attic through both sides of the vent.

Ridge vents without an external baffle were ineffective, failing to create the low air pressure needed to exhaust attic air through both sides of the vent. As a result, testers concluded that “an external baffle was the most significant contributor to the performance of a ridge vent.”

WIND TURBINES

Wind turbines use a moving part to help exhaust air from an attic. That moving part consists of a series of specially shaped vanes that turn wind force into a rotary motion. As the spinning vanes gain velocity, they create an area of low air pressure. That low pressure, in turn, pulls air from an attic.

Although not as effective as ridge vents, wind turbines provide a low-cost alternative in areas where consistent wind speeds of at least 5 mph are typical. Without that minimal wind speed, wind turbines act essentially as roof louvers.

When the wind is blowing, however, wind turbines can be effective air movers.

To provide maximum ventilation benefits, wind turbines, like roof louvers, must be equally spaced along a roof. Otherwise, ventilation will be focused in the area surrounding the wind turbine, allowing hot spots to develop in other areas of the attic.

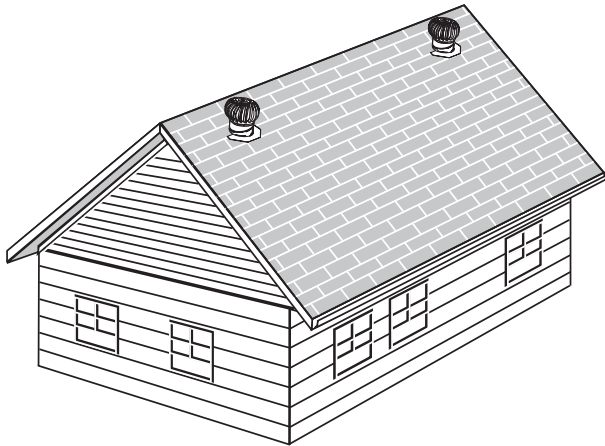

Figure 7-24: Wind turbines are located near the ridge and are used to exhaust air from the attic.

POWER ATTIC VENTILATORS

Like a wind turbine, a power fan uses the rotary motion of blades to draw hot air from the attic. But instead of using wind power to drive the blades, power fans use electricity to drive high-efficiency motors or sunlight if they are solar powered.

Unlike a wind turbine, however, the effectiveness of a power fan isn’t dependent on wind force. Instead, a power fan is turned on and off as needed, automatically, with thermostat and humidistat controls. (In some models, an integral humidistat control is standard; in most models, however, a humidistat is an add-on option. Generally, solar powered fans do not have thermostat or humidistat controls.)

Depending on the size of the motor and the efficiency of the blade design, power fans can move more than 1,500 cubic feet of air per minute. That high volume of air movement is critical. To ensure adequate ventilation, power fans must provide at least 10 changes of attic air every hour.

Although a power fan can move a large volume of air, typically a single unit cannot “vacuum” all hot air from an attic. Usually, to provide uniform air movement along the underside of roof sheathing, a series of power fans must be spaced equally along a roof.

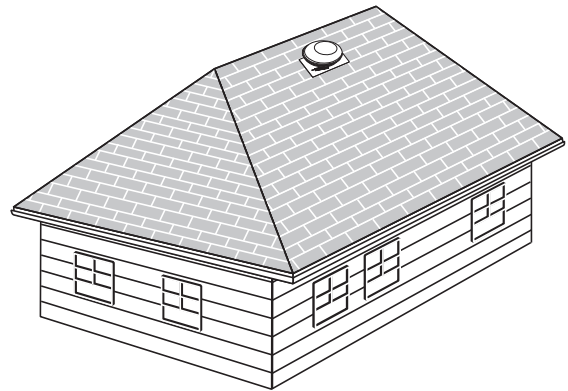

Figure 7-25: Power fans are used to move large volumes of air — a good option for hard-to-vent hip roofs.

When evaluating the feasibility of using power fans, it’s important to evaluate one factor which is considered to be a major disadvantage: namely, that power fans cannot vent away moisture during the winter unless they are equipped with humidistat controls.

If this is a problem in your climate, it can be solved, by using a power fan that has a humidistat control. When that’s done, power fans do offer key benefits. They ensure a high volume of airflow, even on days when outside air is virtually still (a common occurrence in inland areas on hot summer days).